

# Fuse-link D0

### Technical data

Rated voltage $U_n$	400 V AC, 250 V DC
Rated current $I_n$	D01 2 - 16 A, D02 20 - 63 A, D03 80 - 100 A
Breaking capacity at $1,1 U_n$	50 kA AC $\cos \phi = 0,1$ 8 kA DC $T = 15 \text{ ms}$
Fusing characteristics	gG
Standards	DIN EN 60269-1, IEC 60269-1:2005-04 (VDE 0636 Teil 10): 1999-11 DIN EN 60269-3, IEC 60269-3:2003 (VDE 0636 Teil 30): 1995-12 DIN EN 60269-3-1, IEC 60269-3-1: 2004-07 (VDE 0636 Teil 301): 1998-01 DIN VDE 0635/02.84

### D01 gG for fuse base E 14

$I_n$ [A]	dimension $\varnothing A$
2	7,3
4	7,3
6	7,3
10	8,5
13	8,5
16	9,7

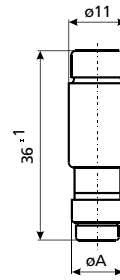

### D02 gG for fuse base E 18

$I_n$ [A]	dimension $\varnothing A$
20	10,9
25	12,1
32	13,3
35	13,3
40	13,3
50	14,5
63	15,9

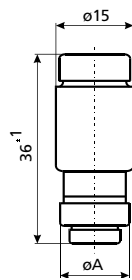

### D03 gG for fuse base M 30 x 2

$I_n$ [A]	dimension $\varnothing A$
80	21,4
100	21,4

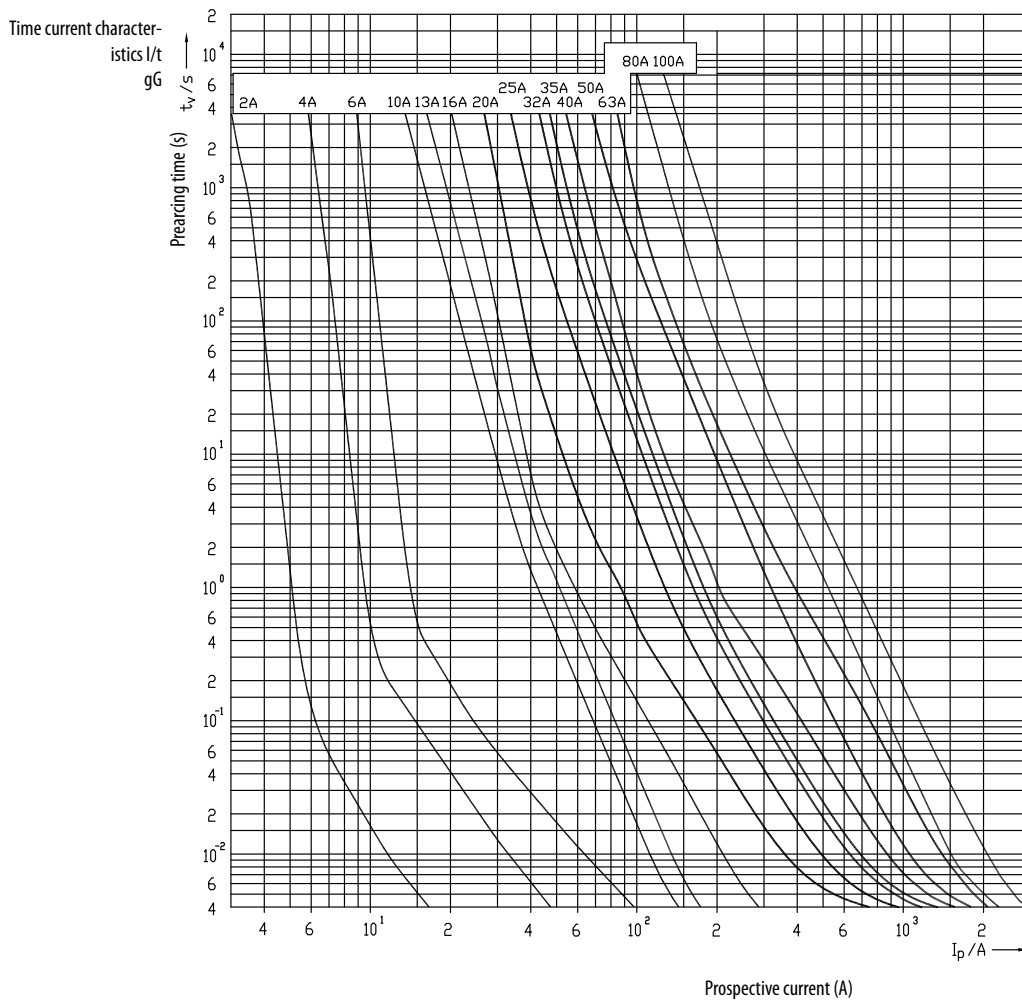
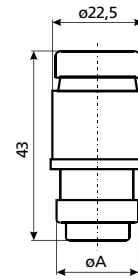

Technical data

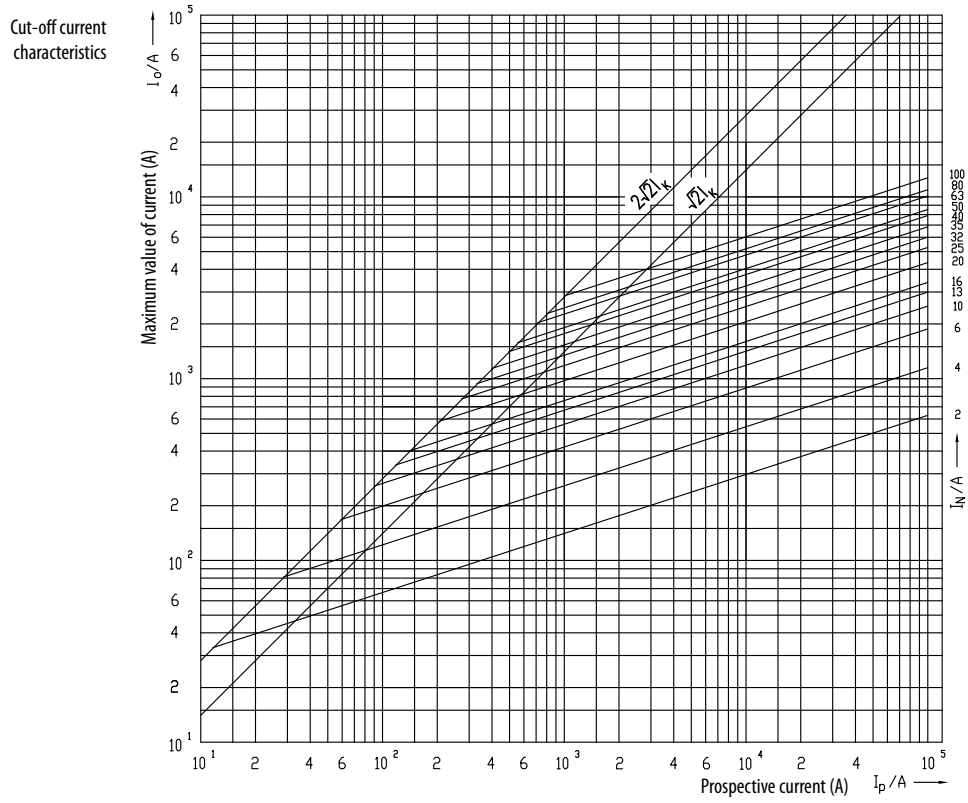

Melting energy characteristics  $I^2t$

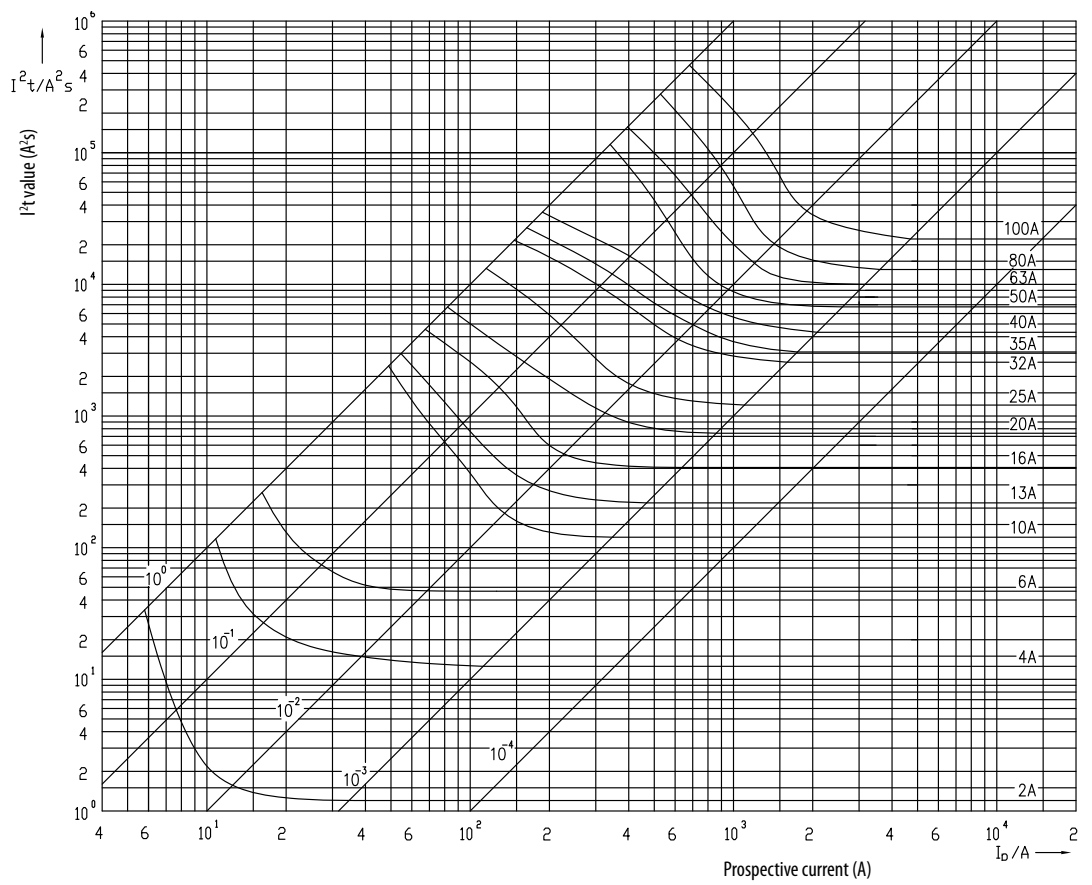

Plastic fuse base PFB D0

Technical data		
	PFB D01	PFB D02
Fuse type	D01	D02
Versions	w/o indicator, LED indicator version	
Number of poles	1p, 3p	
Thread	E14	E18
Rated operational voltage Ue	400V a.c. / 250V d.c.	
Rated operational current Ie	16A	63A
Rated frequency	45-62Hz	
Rated conditional short-circuit current	50kA a.c. / 8kA d.c.	
Max power dissipation of the fuse-link (W)	2,5W	5,5W
LED indicator operating range	50V-400V a.c. / 50V-250V d.c.	
Glow wire test (GWFI)	960°C	
Terminals		
Screw	PZ2 M5	
Torque	2Nm	2,5Nm
Input terminal	1 ... 35mm <sup>2</sup> + Busbar 16mm <sup>2</sup>	
Output terminal	1 ... 25mm <sup>2</sup>	
Humidity		
Operating ambient temperature	90% / 20°C	
Store ambient temperature	-5°C ... +40°C	
Degree of protection (IEC 60529) with fuse - carrier	-25°C ... +55°C	
Mounting on EN 60715 rail	IP 20	
	35mm	
Standards	IEC 60269-3, VDE0636-3	
Approvals	VDE, OVE	

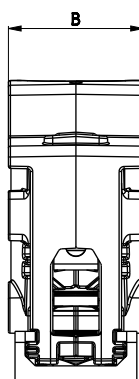
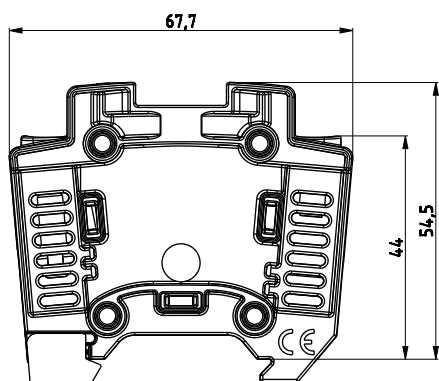

type	B [mm]
1p	26,8
3p	80,4

## Technical data

### Ceramic fuse base

#### Technical data

Rated voltage $U_n$	400 V AC
Rated current $I_n$	D01 16 A, D02 63 A
Cross-section of connecting lead	D01 1 - 4 mm <sup>2</sup> D02 1,5 - 25 mm <sup>2</sup>
Connection clamp	with screw +- PZ
Standards	IEC 60269, EN 60269, DIN VDE 0636, SIST EN 60269

#### 1-pole fuse base D0

type	connections		cross-section of connecting lead [mm <sup>2</sup> ]	dimension A [mm]
	outlet	supply		
D01N - K			1,5 - 4	53
D01V - K			1,5 - 4	53
D02N - K			2,5 - 25	57
D02V - K			2,5 - 25	57
D02N M5 - K			2,5 - 25	57
D02V M5 - K			2,5 - 25	57
D01N			1,5 - 4	53
D01V			1,5 - 4	53
D02N			2,5 - 25	57
D02V			2,5 - 25	57
D02N M5			2,5 - 25	57
D02V M5			2,5 - 25	57

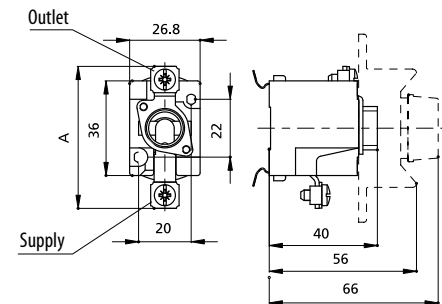

#### 3-pole fuse base D0

type	connections		cross-section of connecting lead [mm <sup>2</sup> ]	dimension A [mm]
	outlet	supply		
D01N/3 - K			1,5 - 4	53
D01V/3 - K			1,5 - 4	53
D02N/3 - K			2,5 - 25	57
D02V/3 - K			2,5 - 25	57
D02N/3 M5 - K			2,5 - 25	57
D02V/3 M5 - K			2,5 - 25	57
D01N/3			1,5 - 4	53
D01V/3			1,5 - 4	53
D02N/3			2,5 - 25	57
D02V/3			2,5 - 25	57
D02N/3 M5			2,5 - 25	57
D02V/3 M5			2,5 - 25	57

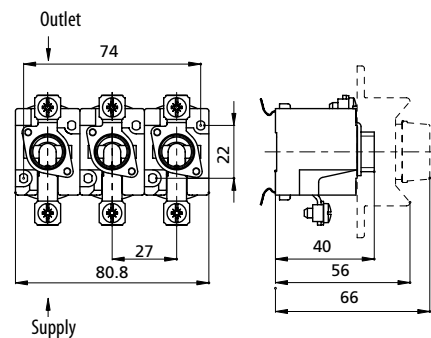

Protection cover

	A [mm]
ZP D01	17,3
ZP D02	21,1

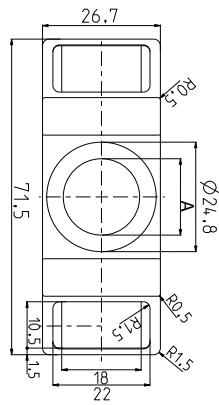

D01, D02

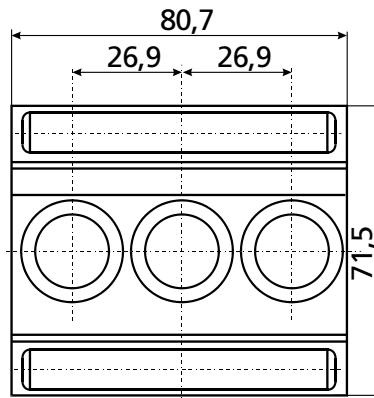

D01/3, D02/3

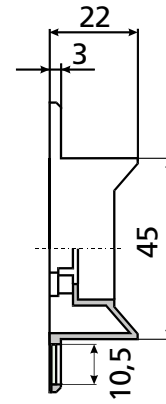

Gauge piece

V D01 for fuse base E 14

I <sub>n</sub> [A]	dimension	
	ØA	ØB
2	7,9	12
4	7,9	12
6	7,9	12
10	9,1	12

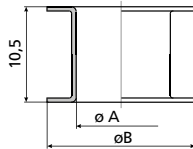

V D02 for fuse base E 18

I <sub>n</sub> [A]	dimension	
	ØA	ØB
2*	7,9	16,6
4*	7,9	16,6
6*	7,9	16,6
10*	9,1	16,6
16*	10,3	16,6
20	11,5	16,6
25	12,7	16,6
35	13,9	16,6
50	15,1	16,6

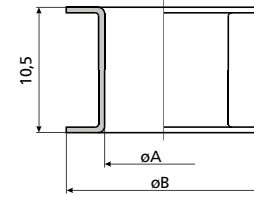

\*For using fuse-links D01 and fuse bases D02.

Fuse carrier D0

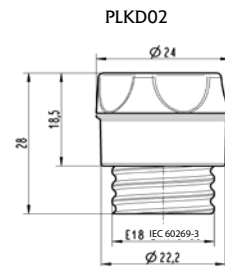
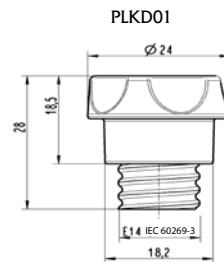
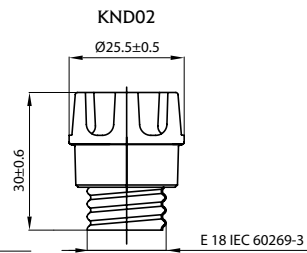
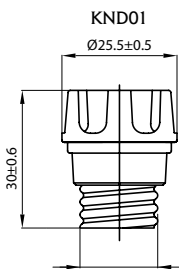

## Technical data

### Fuse - switch disconnecter VLD01

#### Technical data:

Rated voltage $U_n$	230 V, 230/400 V, 400 V a.c.
Rated current $I_n$	2-6 A, 10 A, 13 A, 16 A
Rated frequency $f_n$	45-62 Hz
Utilization category	AC-22 A
Mechanical life	10.000 cycles
Electrical life	1500 cycles
Poles	1p, 1p+N, 2p, 3p, 3p+N
Standards	IEC/EN 60947-1 IEC/EN 60947-3 DIN EN 60947-1 VDE 0660-100 DIN EN 60947-3 VDE 0660-107 IEC 60269-1 Ed. 4.1 2009-07 IEC 60269-3 Ed. 4.0 2010-05
Terminal capacity	1,5 - 25mm <sup>2</sup>

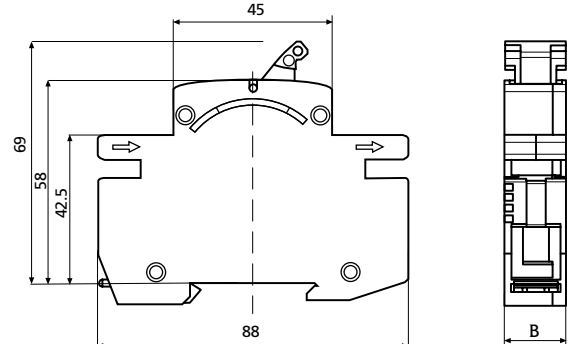

type	B [mm]
1p	17,5
1p+N	35
2p	35
3p	52,5
3p+N	70

### Switch - disconnecter - fuse STVD02

#### Technical data

Number of poles	1p, 1p+N, 2p, 3p, 3p+N
Rated voltage	230/400 V a.c., 110 V (2p) d.c.
Rated current	63 A
Rated breaking capacity	50 kA
Rated insulation voltage	400 V
Rated impulse resistance voltage	6000 V
Category of use according to DIN VDE 0638	AC 22 (63 A), AC 23 (35 A), DC 22 (63 A)
Category of use according to DIN E 60 947-3	AC-22A (63A/400V AC), AC-23A (35A/400V AC), DC-22B (63A/110V DC)
Mechanical life	8.500 cycles
Electrical life	1.500 cycles
Temperature of environment	-5°C ... +40°C
Air humidity	90%
Degree of protection	IP 00 according to DIN 40 050
Standards	IEC/EN 60947-1 IEC/EN 60947-3 DIN EN 60947-1 VDE 0660-100 DIN EN 60947-3 VDE 0660-107 IEC 60269-1 Ed. 4.1 2009-07 IEC 60269-3 Ed. 4.0 2010-05
Terminal capacity	1,5 - 35mm <sup>2</sup>
Possibility of sealing	in ON or OFF position

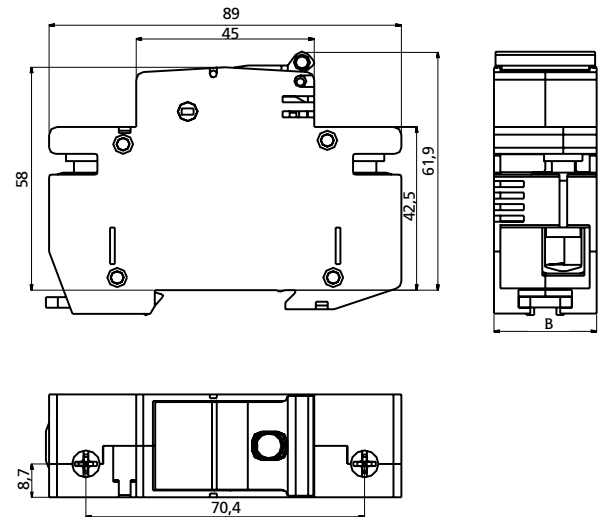

type	B [mm]
1p	26,8
1p+N	53,6
2p	53,6
3p	80,4
3p+N	107,2

## Auxiliary switch PS STV

Technical data:	
Rated current $I_n$	AC12 (6A/230V AC)
	DC12 (1A/110V DC)
Rated conditional short circuit current	1 kA at 20 A fuse link
Standards	EN 62019

