

MCBs - Miniature circuit breakers ETIMAT

Advantages of miniature circuit breakers ETIMAT 6

→ Sealing possibility



→ "ON/OFF" mark on the switch button

→ Option of mounting auxiliary devices (auxiliary switch, shunt trip)

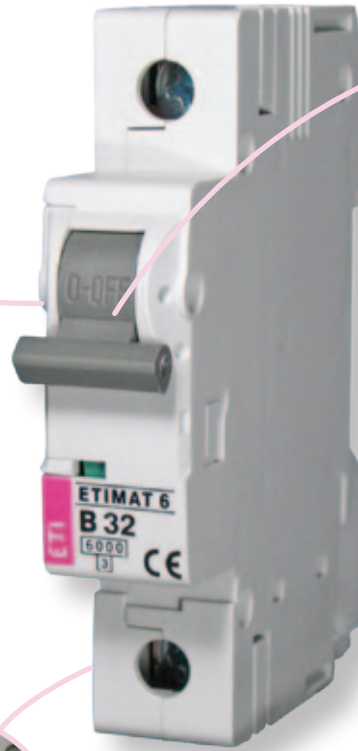
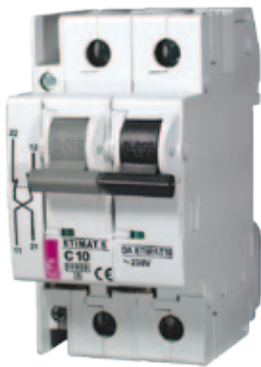

→ Better protection of terminals against touching the parts under voltage



→ Double connection possibility

→ Every product is marked with EAN Code

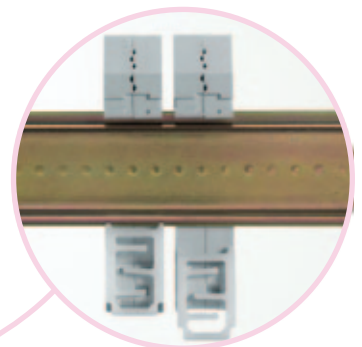
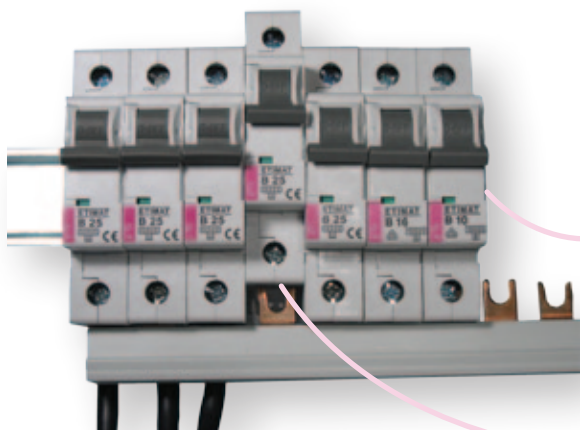

→ New method of mounting on the DIN rail and simple replacement

Miniature circuit breaker ETIMAT 6

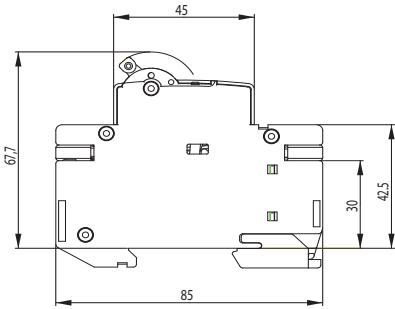

Technical data	
Rated voltage	230/400 V AC, max. 60 V DC
Rated current	B:6-63A, C:0.5-63A, D:0.5-63A
Rated frequency	50/60 Hz
Rated short-circuit capacity	6 kA
Energy limiting class	3; B, C
Tripping characteristic	B, C, D
Terminals	1 – 25 mm ² , max. 3 Nm
Build-in width	18 mm/pol
Mounting on the rail	EN 60715 (EN 50022)
Sealing possibility	ON / OFF
Electrical endurance (op. c.)	4.000
Mechanical endurance (op. c.)	10.000
Overvoltage category	III
Standards	IEC 60898, EN 60898

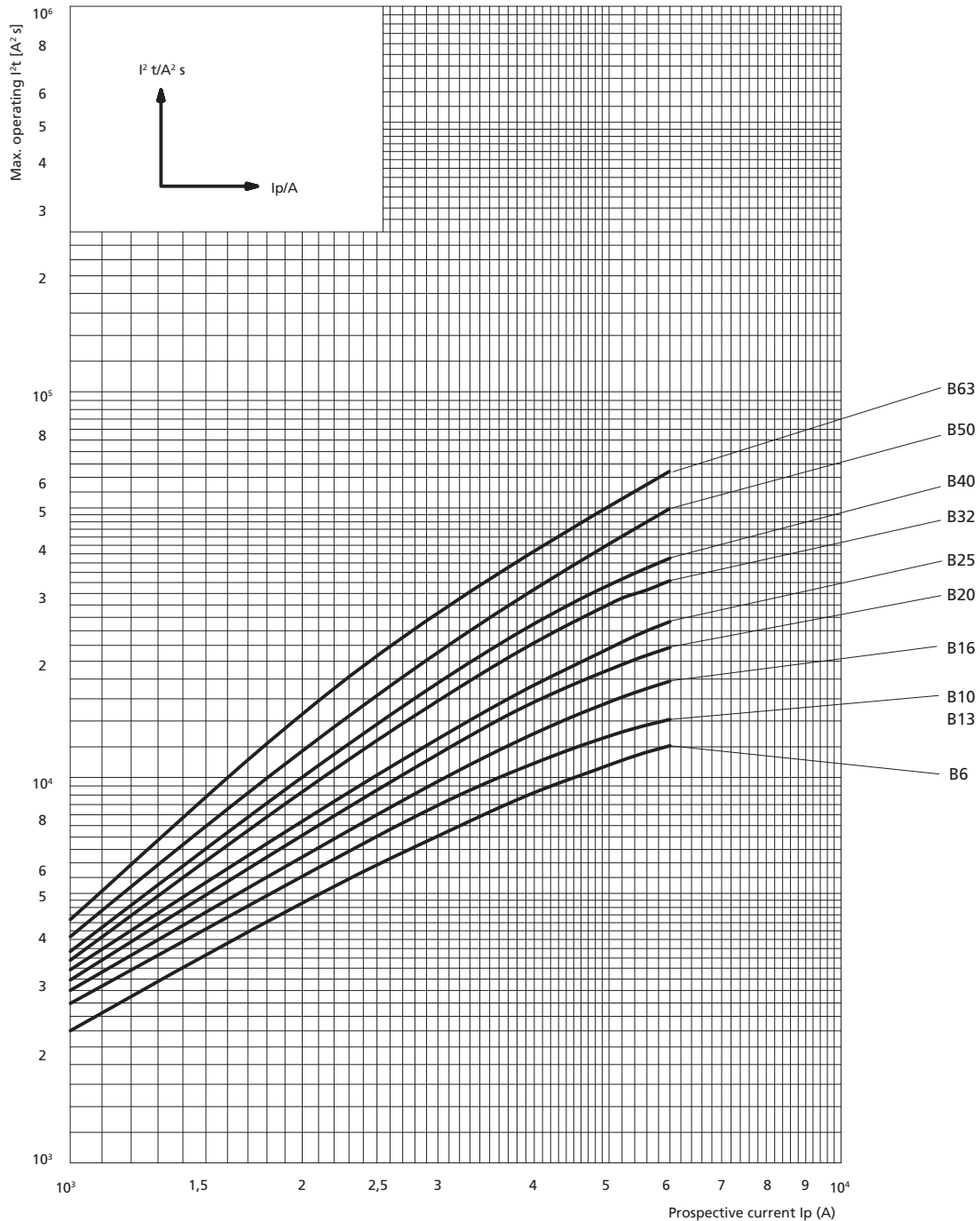

Technical data

Tripping characteristics

Characteristic	Test current	Tripping time	Result
B, C, D	$1,13 I_n$	$t \geq 3600 \text{ s}$	No tripping
B, C, D	$1,45 I_n$	$t < 3600 \text{ s}$	Tripping
B, C, D	$2,55 I_n$	$1 \text{ s} < t < 60 \text{ s}$	Tripping
B	$3,00 I_n$	$t \leq 0,1 \text{ s}$	No tripping
C	$5,00 I_n$	$t \leq 0,1 \text{ s}$	No tripping
D	$10,00 I_n$	$t \leq 0,1 \text{ s}$	No tripping
B	$5,00 I_n$	$t < 0,1 \text{ s}$	Tripping
C	$10,00 I_n$	$t < 0,1 \text{ s}$	Tripping
D	$20,00 I_n$	$t < 0,1 \text{ s}$	Tripping

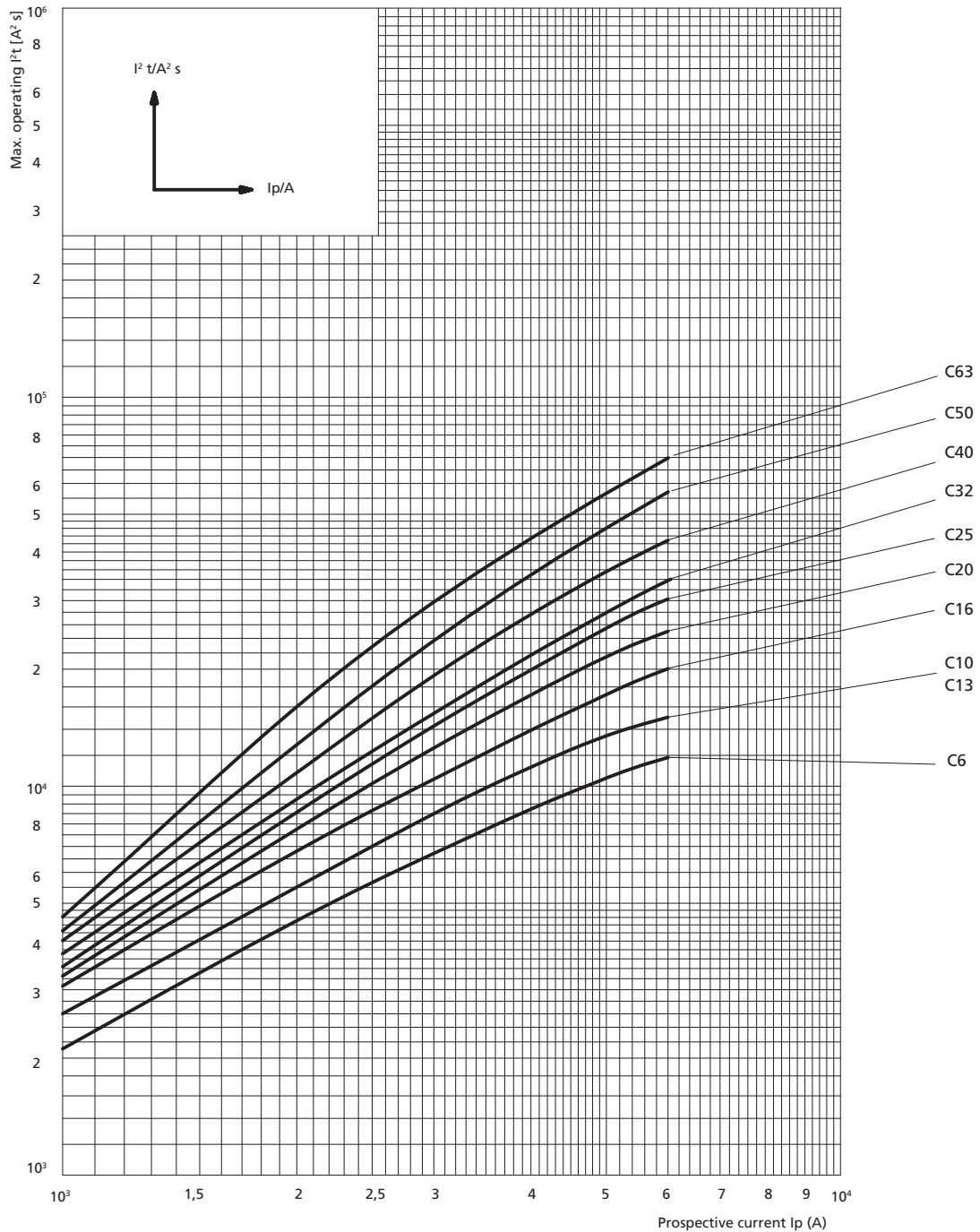
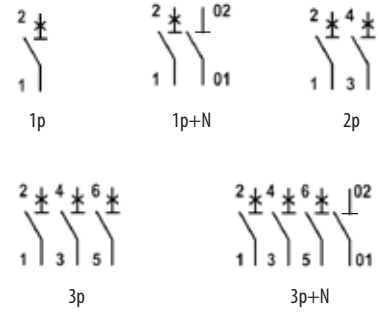

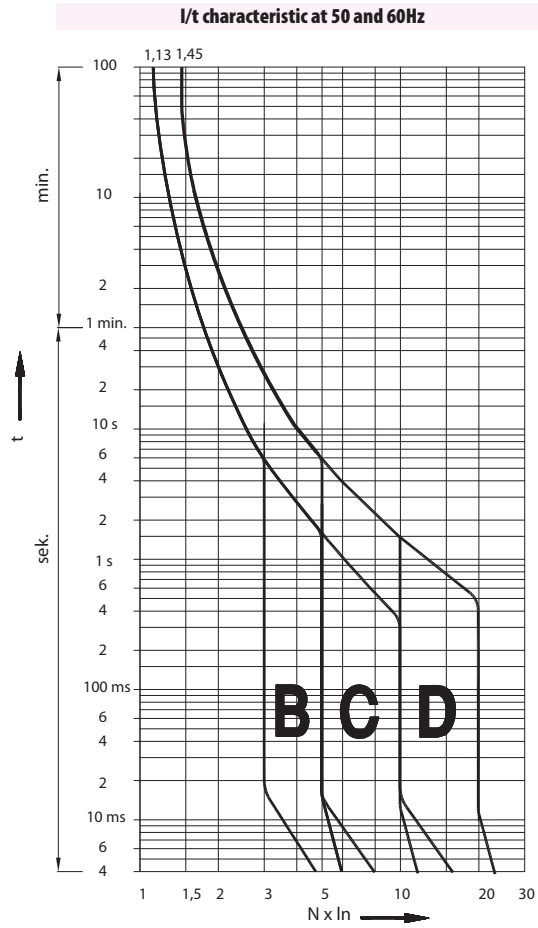

Effect of the ambient temperature on the tripping characteristic

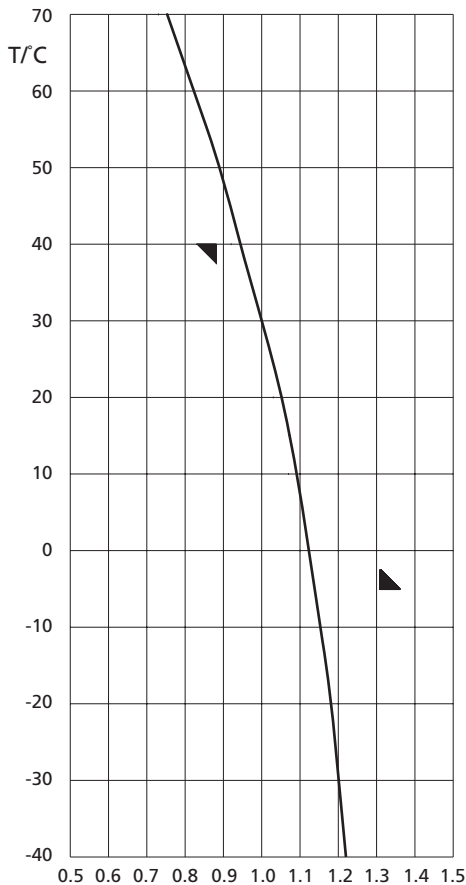

I _n [A]	Ambient temperature T/°C												
	-40	-30	-20	-10	0	10	20	30	40	50	60	70	
0,5	0,61	0,6	0,59	0,57	0,56	0,54	0,52	0,5	0,47	0,44	0,41	0,38	
1	1,22	1,2	1,18	1,15	1,12	1,09	1,05	1	0,94	0,88	0,82	0,75	
1,6	1,95	1,92	1,89	1,84	1,79	1,74	1,68	1,6	1,51	1,42	1,32	1,2	
2	2,44	2,4	2,36	2,30	2,24	2,18	2,1	2	1,88	1,77	1,65	1,5	
4	4,88	4,8	4,72	4,61	4,49	4,36	4,20	4	3,77	3,55	3,29	3	
6	7,32	7,2	7,09	6,91	6,73	6,54	6,31	6	5,66	5,33	4,94	4,5	
10	12,2	12	11,8	11,5	11,2	10,9	10,5	10	9,44	8,89	8,23	7,5	
13	15,9	15,6	15,4	14,9	14,5	14,1	13,6	13	12,2	11,5	10,7	9,75	
16	19,5	19,2	18,9	18,4	17,9	17,4	16,8	16	15,1	14,2	13,2	12	
20	24,4	24	23,6	23	22,4	21,8	21	21	18,8	17,7	16,5	15	
25	30,5	30	2,5	28,8	28	27,2	26,3	25	23,6	22,2	20,6	18,8	
32	39	38,4	37,8	36,9	35,9	34,9	33,6	32	30,2	28,4	26,3	24	
40	48,8	48	47,8	46,1	44,9	43,6	42	40	37,7	35,5	32,9	30	
50	61	60	59,1	57,6	56,1	54,5	52,6	50	47,2	44,4	41,2	37,5	
63	76,9	75,6	74,4	72,6	70,7	68,7	66,2	63	59,4	56	51,9	47,3	

Correction factor is valid for current with times over 30 s
 I(x°C) - test current at x ambient temperature
 I(30°C) - test current at 30°C ambient temperature

$$k = \frac{I(x^\circ\text{C})}{I(30^\circ\text{C})}$$

Technical data

Resistance and power loss

characteristic	I_n [A]	R [mΩ]	P [w]
C, D	0,5	4500	1,12
	1	1800	1,80
	1,6	450	1,15
	2	280	1,08
	4	110	1,70
B, C, D	6	29	1,08
	10	13	1,30
	13	11,6	2,00
	16	9,0	2,30
	20	5,3	2,00
	25	4,1	2,50
	32	2,6	2,70
	40	1,96	3,20
50	1,5	4,00	
63	1,15	4,80	

Selectivity

ETIMAT	gG NV											
	20	25	32	35	40	50	63	80	6,00	125	160	
B 6	0,5	0,78	1,2	1,4	1,7	2,4	4,6	6,0	6,0	6,0	6,0	
B 10/13	0,45	0,65	1,1	1,3	1,6	2,2	4,0	6,0	6,0	6,0	6,0	
B 16		0,55	1,0	1,2	1,5	2,0	3,6	5,5	6,0	6,0	6,0	
B 20			0,85	1,2	1,5	1,8	3,1	4,6	6,0	6,0	6,0	
B 25				1,1	1,4	1,7	2,9	4,0	6,0	6,0	6,0	
B 32					1,3	1,6	2,5	3,4	5,5	6,0	6,0	
B 40						1,5	2,2	3,1	4,9	6,0	6,0	
B 50							2,1	2,9	4,0	6,0	6,0	
B 63								2,5	3,3	5,1	6,0	

ETIMAT	gG NV											
	20	25	32	35	40	50	63	80	6,00	125	160	
C,D 6	0,52	0,82	1,3	1,5	2,0	2,7	5,1	6,0	6,0	6,0	6,0	
C,D 10/13	0,47	0,70	1,1	1,4	1,8	2,3	4,0	6,0	6,0	6,0	6,0	
C,D 16		0,61	0,92	1,2	1,5	1,9	3,2	5,0	6,0	6,0	6,0	
C,D 20			0,90	1,1	1,4	1,7	2,9	4,2	6,0	6,0	6,0	
C,D 25				1,0	1,3	1,6	2,7	3,9	6,0	6,0	6,0	
C,D 32					1,2	1,5	2,3	3,4	5,2	6,0	6,0	
C,D 40						1,4	2,1	3,0	4,6	6,0	6,0	
C,D 50							2,0	2,7	3,8	6,0	6,0	
C,D 63								2,3	3,2	5,5	6,0	

Miniature circuit breaker ETIMAT 1N

Technical data

Rated voltage U_n	230 V AC
Rated current I_n	6-32 A
Rated frequency f_n	50/60Hz
Rated short-circuit capacity	6.000 A
Back-up fuse	100 A gG
Tripping characteristics	B, C
Overtoltage category	III
Energy limiting class	3
Terminals	1-10mm ² , max. 1,5Nm
Build-in width	18mm
Standard	IEC 60898, EN 60898

Description

Miniature circuit breaker ETIMAT 1N is a device with protected line pole and switched neutral pole.

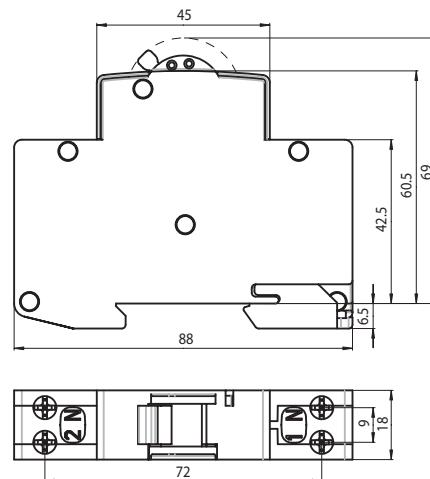

Advantages:

- 1-pole+N in single housing
- Sealing possibility
- Indication of contacts' state
- New method of mounting on the DIN rail and simple replacement

Auxiliary switch PS ETIMAT

Technical data

Rated current	6A (230V AC), 1A (110V DC), 0,5A (220V DC)
Terminal	1-4mm ²
Contact	1 xb-contact (NC) 1 xa-contact (NO)
Conditional short-circuit current	1 kA with fuse-link 20 A
Standard	EN-62019

PS ETIMAT is an auxiliary switch used for remote signalling of the MCB to which it is fixed. PS ETIMAT may also be fixed later of the state. Clamps are safe to touch. External dimensions comply with MCB, built-in width is 0,5 module (9 mm). During fitting, the MCB must be switched off.

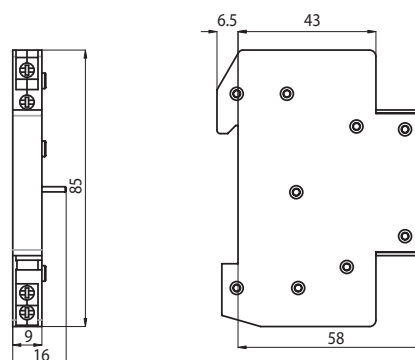

PS ETIMAT is an auxiliary switch only for ETIMAT 6.

Shunt trip release DA ETIMAT

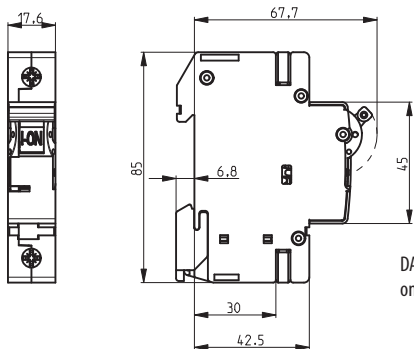

DA ETIMAT is a shunt trip release only for ETIMAT 6.

Technical data	
Nominal voltage	24V AC/DC, 48V AC/DC, 230V AC/DC
Rated frequency	50/60Hz
Max. inrush current	3,6 A
Build-in width	18mm
Mounting on the rail	EN 60715 (EN 50022)

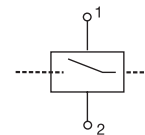

DA ETIMAT shunt trip release is fixed to the right side of the miniature circuit breaker ETIMAT for remote release of the MCB. Dimensions correspond to those of MCB ETIMAT.